

## **Enhanced Accident Prevention System in Underground Collieries Using Labview**

Govindaraj K <sup>(1)</sup>, Vikneshwaran G <sup>(2)</sup>, Karthick K <sup>(3)</sup>, Tamilamban P<sup>(4)</sup>  
<sup>1,2,3,4</sup> Student Members, Department Of EEE.  
SONA College Of Technology, Salem, India.

---

**ABSTRACT:** In the present scenario the major mine disaster takes place through explosion, fire and suffocation. This project aims in implementing the latest technology LabVIEW, through our “Enhanced Accident Prevention System in Underground Collieries Using LabVIEW“. The proposed system comprises of Compressed Natural Gas(CNG) sensor, a Driver circuit & a Blower connected to the LabVIEW where the concentration of methane present in underground coal mine can be monitored. A control signal is generated by LabVIEW, when the methane gas concentration reaches (400-1000ppm), the Blower sucks the air from the atmosphere and blows into the underground coal mine field, in order to dilute the methane gas. In case of Blower failure, an electromagnetic relay which is present at the Blower detects & indicates the fault to LabVIEW. LabVIEW is programmed in such a way that automatic switching is made to a standby Blower and the information is sent to the mechanical and electrical department by means of audio information. In case of unpredictable failure in the Blower the information is also sent to the rescue team in order to alert them. At the same time when the methane concentration reaches a particular level the alert rescue signal is sent to rescue team, to safeguard the miners. As the explosion takes place due to increase in methane concentration during this critical situation, the emergency signal is sent to the fire and police department through GSM network using LabVIEW. Apart from these safety measures, in case of any personal health problem for the miners working underground, a health trigger is provided inside the mine, when the trigger is pressed in case of emergency condition the information is sent to the first aid and rescue team via LabVIEW to the speakers.

**KEYWORDS:** CNG, Mine Disaster, Explosion, LabVIEW, GSM, Health Trigger.

---

### **I. INTRODUCTION**

The coal mining process in India was established in the year of 1774 by **John Sumner** and **Suetonius Grant Harry** of the East India Company in the **Raniganj Coal Field**. Further it is expanded all over India with large amount of production. India is the third largest producer of coal in the world compared with China at first place and the US at second. The coal in India is under the Government sector. The mining, exploitation and utilization of coal are done by various Indian companies in which CIL and its associated companies are the major ones [16]. In addition to CIL, the NLC operates the Neyveli mines in Tamil Nadu State, Singareni Collieries Ltd. operates the bituminous mines in Andhra Pradesh and Tata Iron and Steel Company (TISCO) operates mines in Bihar to supply coking coal to their own steel plants. CIL is divided into a number of subsidiaries for operational purposes. These are Eastern Coalfields Ltd. (ECL), Bharat Coking Coal Ltd. (BCCL), Central Coalfields Ltd. (CCL), Northern Coalfields Ltd (NCL), South Eastern Coalfields Ltd. (SECL), Mahanadi Coalfields Ltd. (MCL) and Western Coalfields Ltd. (WCL). There is also another principal subsidiary of CIL, the Central Mine Planning and Design Institute Ltd. (CMPDIL). From the day coal mining is started, the major issue faced by the miners is **Safety**. As per the statement of the **Chairman, Coal India Limited, Mr Partha S. Bhattacharya** [6]

**“WE HAVE NOT BEEN ABLE TO IMPROVE MINE SAFTY STANDARDS IN THE LAST 4/5 YEARS DUE TO LACK OF TECHNOLOGY”**

The **Coal Mine Safety Act** was passed in **1974** by Indian Government and formed a committee headed by Directorate general of Mine Safety. They examined problems faced by the miners and the factors that lead to disaster [6]. They came up with large number of solutions with lack of technology as stated by the Chairman, Coal India Limited. Thus these solutions are being documented without any Implementation. The statistics of India are chilling. As per the statistics shown by the Indian Ministry of Coal, **455 thousands of miners** are undergoing serious accidents [6].

COMP ANY	FATAL ACCIDENTS				FATALITIES				SERIOUS ACCIDENTS				SERIOUS INJURIES			
	2007	2008	2009	2010	2007	2008	2009	2010	2007	2008	2009	2010	2007	2008	2009	2010
BCCL	9	11	14	9	9	11	18	9	59	48	41	21	60	48	44	26
CCL	7	4	6	8	8	4	6	10	21	18	6	8	22	19	8	9
ECL	7	11	8	12	8	11	9	12	12	11	11	53	13	11	11	53
MCL	4	4	3	2	4	4	3	2	8	5	6	3	8	5	6	3
NCL	6	5	4	12	6	9	4	12	12	8	2	7	13	8	2	7
NEC	0	2	0	1	0	7	0	1	0	0	0	0	0	14	0	0
SECL	14	11	9	20	14	12	9	33	71	54	35	36	75	55	38	44
WCL	12	11	11	13	12	13	13	16	53	29	38	37	54	29	39	41
CIL	59	59	55	77	61	71	62	95	34	27	23	16	36	29	24	183
SCCL	10	12	17	10	10	13	21	12	55	42	40	29	56	42	41	308
NLC	2	2	3	2	2	2	3	3	4	3	8	4	7	3	9	5

Table I  
Accident Statistics During The Period 2007-2010

## II. EXISTING SYSTEM

The major mine disasters takes place through explosion, fire and suffocation. These explosions occur due to the process called Coal Gasification [7][15]. Coal gasification is the process where coal reacts with oxygen and moisture present in the mines to produce Syngas(Combination of Hydrogen and Carbon monoxide) ("GASIFICATION"). The toxic gas carbon monoxide in turn reacts with moisture to produce carbon dioxide and hydrogen.

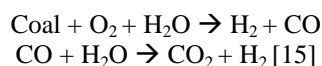

Thus the resultant hydrogen from both the above reactions combine with carbon monoxide to form the highly toxic Methane Gas along with moisture and large amount of Energy. The methane gas obtained, on combustion with oxidizing agent such as  $\text{O}_2$ ,  $\text{H}_2\text{O}_2$ ,  $\text{F}_2$ ,  $\text{Cl}_2$ ,  $\text{N}_2\text{O}$ , etc becomes highly explosive, if Methane Concentration level reach 5-15%. Methane explosions are devastating causing significant loss of life & damage of property.

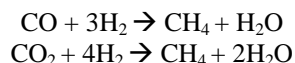

From the above two reactions the amount of methane released increases in ppm(parts per million) and this starts reacting with oxygen to form toxic gas which on further increase cause suffocation to human.

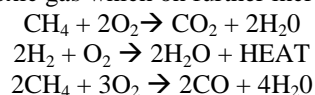

The Methane gas can be diluted before it reaches (5-15) % value of its concentration by pumping atmospheric air. Failure to provide enough air to dilute methane below (5-15) % range can put miners at risk due to the threat of explosion. Thus here we have come up with a widely expanding technology, LabVIEW for the safety of underground coal mines by reducing the methane gas explosion.

### A. Limitations Of Existing System

Some of the Safety measures that are carried out in India are [1][7],

- Breathing apparatus
- Smoke helmets and goggles
- Reviving apparatus
- Electric safety lamps and flame safety lamps

- First aid kit
  - Self rescuers.
  - Safety rooms
- These safety measures can only help the miners after the accidents have taken place.

### III. PROPOSED SYSTEM

#### A. OBJECTIVE

The main objective of our project is,

- To reduce the Human Death Ratio in the Mine explosion & Accidents.
- To inform the status of the emergency condition to various departments.
- If explosion take place, quick transmission of information to emergency care centre to intimate the status of the mines.
- To provide maximum assistance before explosion take place.
- To incorporate the technology and make more versatile applications for the purpose of human safety.

This project comprises of the following components,

- Compressed Natural Gas(CNG) sensor
- RS232
- LabVIEW
- ARDUINO
- AC Drive
- Blower
- Speaker
- First Aid Trigger

#### B. BLOCK DIAGRAM DESCRIPTION

The proposed model is used to identify and indicate the explosion and status of victims in mines and collieries. To indicate the victim status such as Personal Health Problem of a Miner and the emergency information's like Blower Failure, Increase in Methane Concentration, Mine at Risk and some periodic alerts will be transmitted to the various departments like Electrical And Mechanical Department, First Aid Team, Rescue Team and also to the Fire Service And Police through GSM.

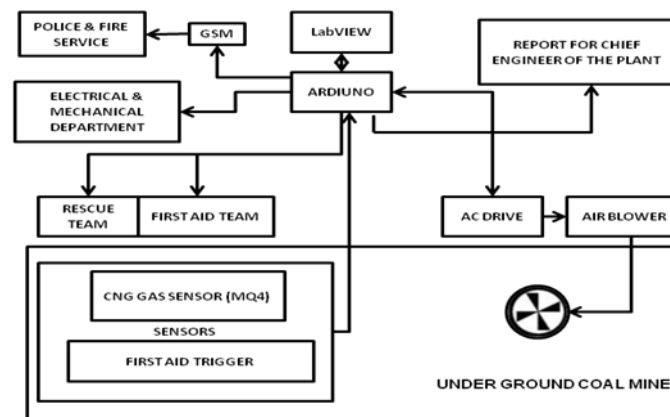

Fig. 1 Block Diagram

The Compressed Natural Gas Sensor is used to sense the Methane Concentration Level in the underground coal mine and is interfaced with LabVIEW software to acquire the data. The same data and analysis report will be transmitted to the Head of Safety Department of coal mine by LabVIEW to the personal computer in the form of a Microsoft Excel Sheet. After developing LabVIEW software, the sensor module has been interfaced through serial communication port. Before interfacing the hardware, the software configuration is done to enable and establish the communication between hardware unit and the LabVIEW software. In the LabVIEW front panel window, HARDWARE INTERFACE box configuration ensures the USB data reception and communication. A control signal is generated by LabVIEW when the methane gas concentration reaches 200ppm (which is before the critical zone), to the Blower through ARDUINO DAQ output. Thus LabVIEW controls the Blower by turn ON/OFF in accordance to the dilution of methane gas.

Before continuous functioning of the entire system, the serial communication port number, methane concentration minimum and maximum value [2], alert signal to siren & buzzer should be set in the LabVIEW window. Presently we have assigned two Blowers for switching operation, incase of any unexpected Blower Failure and each department is provided with siren & buzzer to intimate their help during fault.

As an additional feature, incase of any personal health problem for the miners working underground, a health trigger is provided inside the mine. When the trigger is pressed during emergency condition, the information is sent to the first aid and rescue team in the form of an alert signal by LabVIEW.

### C. OPERATION

Compressed Natural Gas Sensor (MQ4) is placed in the underground mine, in order to measure the toxic methane gas concentration and is visualized using LabVIEW. The sensor module has been interfaced with the LabVIEW through ARDUINO DAQ, by means of an output cable. The increase / decrease in the methane concentration in underground coal mine can be monitored in the LabVIEW window and is viewed in level indicator, graphical view and also in explosion level meter. The other toxic gas like CO is also measured in a level indicator for safety purpose. A control signal is generated by LabVIEW when the methane gas concentration reaches initially to 200ppm (before the critical zone of 400-1000ppm), to the AC Drive of the Blower through the output cable of ARDUINO DAQ. This AC drive circuit controls the Blower which sucks the air from the atmosphere and blows into the underground coal mine field. Thus methane gas is diluted. Incase of Blower failure, an alternate standby Blower is placed and so LabVIEW detects the fault and sends the information to Electrical & Mechanical Department by means of Siren in order to repair them. LabVIEW is programmed in such a way that automatic switching is made to a standby Blower. Incase of unpredictable failure in both the Blowers the information is sent to the Rescue Team by means of a Siren in order to alert them and also to the Mechanical & Electrical Department in order to clear the fault.

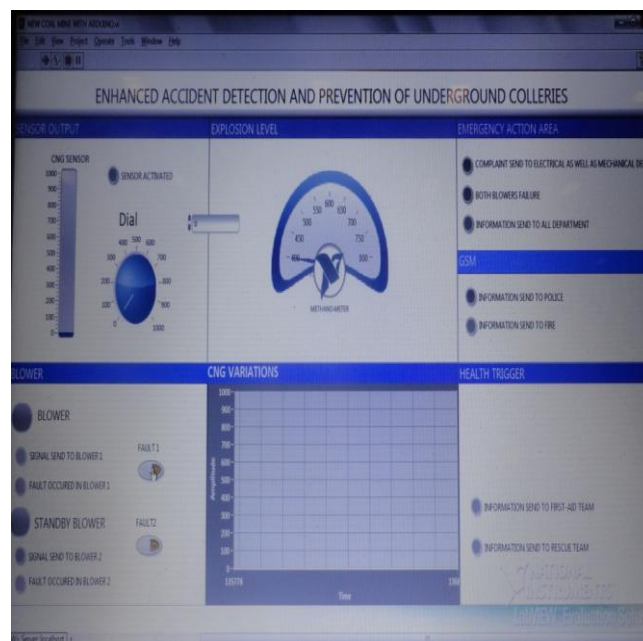

Fig 2 LabVIEW Front Panel

If in case the methane concentration reaches 200ppm, when both the blowers are failure, then emergency Rescue signal is sent to Rescue Team in the form of continuous Siren, to intimate that miners are at risk. As the explosion take place as when the methane concentration increases to 200ppm and above during this critical situation, an emergency call is made to the Police & Fire Service through GSM network using LabVIEW to limit the explosion at the earliest. Apart from these safety measures, a health trigger is provided inside the mine to avoid loss of life due to personal health problems for the miners working underground. When the trigger is pressed the signal is sent by LabVIEW to the First Aid and Rescue Team by means of a Siren in order to intimate the emergency state under the mine. Now all the conditions like blower failure, personal health problem, mine at explosion state, etc has been transmitted to LabVIEW and the same data in LabVIEW will be transmitted to the Head of Safety Department of the coal mine in the form of an Excel sheet at equal time intervals to intimate the status of the mine.

## D. SYSTEM SPECIFICATION

### A. MQ4 – METHANE GAS SENSOR

The MQ-4 gas sensor can detect the natural gas concentrations present anywhere from (200 to 10000) ppm. This sensor has a high sensitivity and fast response time. The sensor's output is an analog resistance. The drive circuit is very simple with 5v power supply to the heater coil, add a load resistance, and connect the output to an ADC [20]. Structure and configuration of MQ-4 gas sensor, is composed of micro  $AL_2O_3$  ceramic tube, Tin di-oxide ( $SnO_2$ ) sensitive layer, measuring electrode and heater are fixed into a crust made by plastic and stainless steel net. The heater provides necessary work conditions for work of sensitive components. The enveloped MQ-4 have 6 pin, 4 of them are used to fetch signals, and other 2 are used for providing heating current as shown in Fig. 4.



Fig. 3 Compressed Natural Gas Sensor

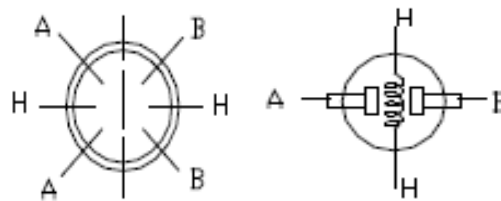

Fig. 4 Pin Diagram of Gas Sensor

#### 1. Features

The various features of the natural gas sensor are [20]:

- High sensitivity to  $CH_4$ , Natural gas.
- Small sensitivity to alcohol, smoke.
- Fast response.
- Stable and long life.
- Simple drive circuit.

#### 2. Sensor Module Connecting and Testing

The Gas Sensor Module is designed to

allow a microcontroller to determine when a preset gas level has been reached or exceeded. Interfacing with these sensors is done through a 4-pin SIP header and requires two I/O pins from the host microcontroller. The sensor modules are intended to provide a means of comparing gas sources and being able to set an alarm limit when the source becomes excessive. The gas sensor canister plugs into the socket on the front of the module. The gas sensors are essentially resistive devices and are not polarized, so there is no need to be concerned about plugging it in "backwards." It will work in either orientation [22]. The 4-pin SIP header on the Gas Sensor Module makes it easy to connect to a breadboard or SIP socket. Connection to a 5V microcontroller, such as the BASIC Stamp module, would be pretty straight forward and require two I/O pins; one input for detecting the alarm signal and the other an output for controlling the internal heater.

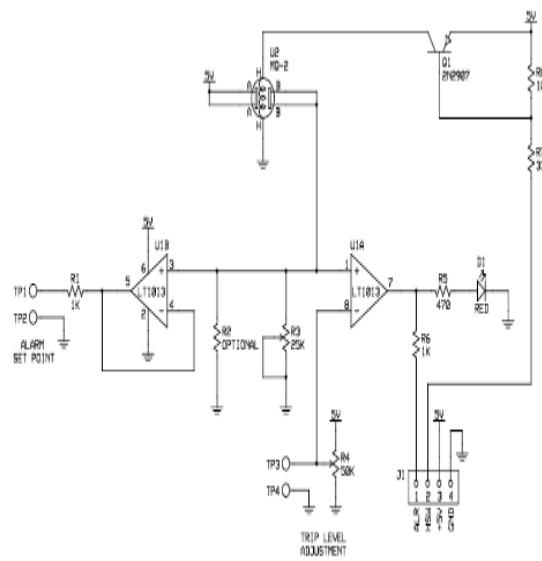

Fig. 5 Connection Diagram of Sensor Module

To interface MQ4 sensor module with Arduino the following programming is done [21]

```

void setup()
{
  Serial.begin(9600); //Set serial baud rate to 9600 bps
}
void loop()
{
  int val;
  val=analogRead(0); //Read Gas value from analog 0
  Serial.println(val,DEC); //Print the value to serial port
  delay(100);
}
    
```

The Fig. 6 shown below gives the connection of Arduino with sensor module and is programmed for data transfer [21].

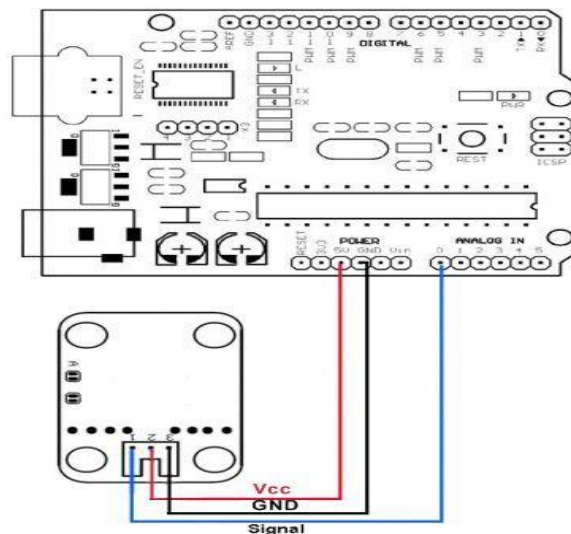

Fig. 6 Interfacing Sensor module with Arduino



## B. GSM

GSM, which stands for Global System for Mobile communications, regions as the world's most widely used cell phone technology. Cell phones use a cell phone service carrier's GSM network by searching for cell phone towers in the nearby area.

### 1) GSM Carrier Frequencies

GSM networks operate in a number of different carrier frequency ranges (separated into GSM frequency ranges for 2G and UMTS frequency bands for 3G), with most 2G GSM networks operating in the 900 MHz or 1800 MHz bands. Where these bands were already allocated, the 850 MHz and 1900 MHz bands were used instead (for example in Canada and the United States). In rare cases the 400 and 450 MHz frequency bands are assigned in some countries because they were previously used for first-generation systems.

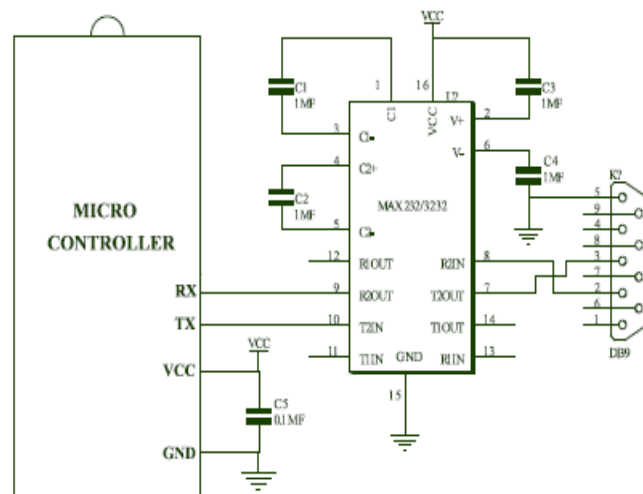

Fig. 7 GSM SIM900 Circuit Diagram

Regardless of the frequency selected by an operator, it is divided into timeslots for individual phones to use. This allows eight full-rate or sixteen half-rate speech channels per radio frequency. These eight radio timeslots (or eight burst periods) are grouped into a TDMA frame. Half rate channels use alternate frames in the same timeslot. The channel data rate for all 8 channels is 270.83 kbit/s, and the frame duration is 4.615 ms. The transmission power in the handset is limited to a maximum of 2 watts in GSM850/900 and 1 watt in GSM1800/1900.

### 2) GSM MODEM

A GSM modem is a wireless modem that works with a GSM wireless network. A wireless modem behaves like a dial-up modem. The main difference between them is that a dial-up modem sends and receives data through a fixed telephone line while a wireless modem sends and receives data through radio waves. A GSM modem can be an external device or a PC Card / PCMCIA Card. Typically, an external GSM modem is connected to a computer through a serial cable or a USB cable. A GSM modem in the form of a PC Card / PCMCIA Card. Typically, an external GSM modem is connected to a computer through a serial cable or a USB cable. A GSM modem in the form of a PC Card / PCMCIA Card is designed for use with a laptop computer. It should be inserted into one of the PC Card / PCMCIA Card slots of a laptop computer. A GSM modem is a specialized type of modem which accepts a SIM card, and operates over a subscription to a mobile operator, just like a mobile phone. From the mobile operator perspective, a GSM modem looks just like a mobile phone. A GSM modem can be a dedicated modem device with a serial, USB or Bluetooth connection, or it may be a mobile phone that provides GSM modem capabilities [19].

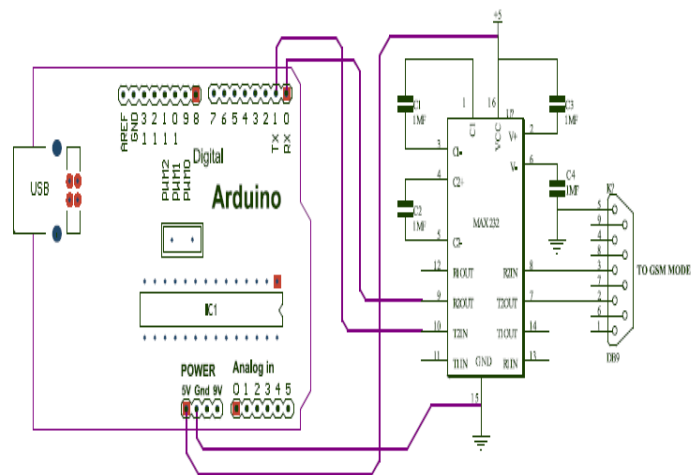

Fig. 8 Arduino interfaced with GSM Module

The GSM modem has given a 5V supply by connecting it with the Arduino module and thus the input to the GSM module is from Arduino and this data transfer is also programmed in Arduino using C-language. The Fig. 8 shows interfacing of GSM module with Arduino

### C. ARDUINO

Arduino is an open-source single-board micro-controller, descendant of the open-source Wiring platform, designed to make the process of using electronics in multidisciplinary projects more accessible. The hardware consists of a simple open hardware design for the Arduino board with an Atmel AVR processor and on-board input/output support. The software consists of a standard programming language compiler and the boot loader that runs on the board [18 b]. Arduino hardware is programmed using a Wiring-based language (syntax and libraries), similar to C++ with some slight simplifications and modifications, and a Processing-based integrated development environment. Current versions can be purchased pre-assembled; hardware design information is available for those who would like to assemble an Arduino by hand. Additionally, variations of the Italian-made Arduino—with varying levels of compatibility—have been released by third parties; some of them are programmed using the Arduino software [18 a].

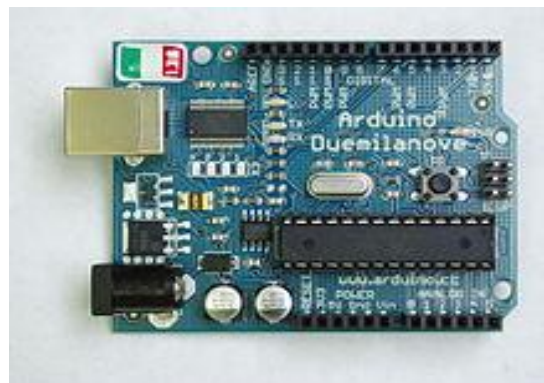

Fig. 9 Arduino UNO Module

#### 1) Hardware

An Arduino board consists of an 8-bit Atmel AVR microcontroller with complementary components to facilitate programming and incorporation into other circuits. An important aspect of the Arduino is the standard way that connectors are exposed, allowing the CPU board to be connected to a variety of interchangeable add-on modules known as shields. Some shields communicate with the Arduino board directly over various pins, but many shields are individually addressable via an I<sup>2</sup>C serial bus, allowing many shields to be stacked and used in parallel [18 a]. Official Arduino have used the mega AVR series of chips, specifically the ATmega8, ATmega168, ATmega328, ATmega1280, and ATmega2560. A handful of other processors have been used by Arduino compatibles. Most boards include a 5 volt linear regulator and



a 16 MHz crystal oscillator (or ceramic resonator in some variants), although some designs such as the LilyPad run at 8 MHz and dispense with the onboard voltage regulator due to specific form-factor restrictions. An Arduino's microcontroller is also pre-programmed with a boot loader that simplifies uploading of programs to the on-chip flash memory, compared with other devices that typically need an external programmer.

## 2) UNO R2 and R3

During fall of 2011, the Arduino team revealed that there will be a new minor revision of the classic Arduino, the "UNO R3" (revision 3). A lot of people have asked us about the R3 so here is everything we know so far [18 a].

- The UNO R3 is backwards compatible with the UNO - same driver, same uploading, same look
- The USB controller chip has moved from an atmega8u2 (8K flash) to an atmega16u2 (16K flash).
- 

```

Swarmcube_Test_Program | Arduino 0022

Swarmcube_Test_Program

/*
 * This simple program receives DTMF tones -
 * when a tone is detected, the cube flashes up and
 * the same tone is played back for a short duration.
 */
#include <Cube.h> // Import the LED-Cube library

void setup() {
  LEDCube.init(); // Initialize the LED-Cube
  LEDCube.clear(0); // Make cube dark
}

void loop() {
  char detected = LEDCube.getNewDTMF();
  if(detected) { // have we received a DTMF-tone?
    LEDCube.clear(WHITE); // Fill cube white
    LEDCube.playDtmf(detected); // Play the same tone back on the speaker
    delay(50); // .. for 50 ms
    LEDCube.stopDtmf(); // then make it quiet again
  } else {
    LEDCube.dimlin(-16); // dim the cube so it fades out.
  }
  LEDCube.sendFrame(); // modified frames need to be sent to the controller
  delay(25); // wait a bit to achieve around 40 fps.
}
    
```

Fig. 10 Arduino Software Programmed using C-language

In order to interface ARDUINO with LabVIEW the Arduino software is first programmed using c-language in PC and this program is linked with the LabVIEW block diagram shown in Fig. 11.

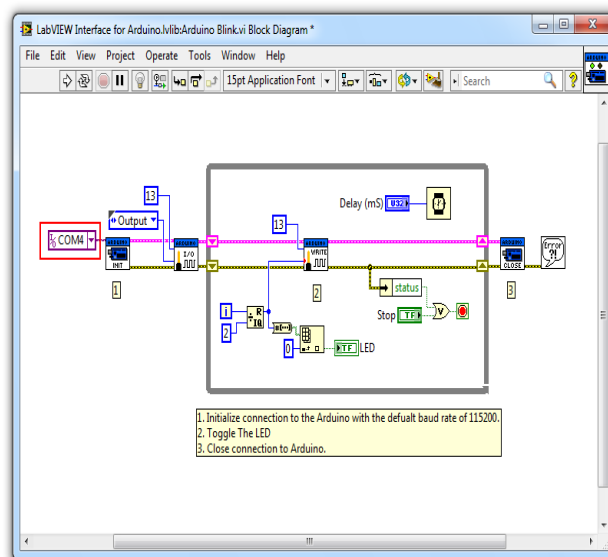

Fig. 11 LabVIEW Block Diagram Linked with Arduino

#### IV. CONCLUSION

This project will be a mile stone for the prevention of death due to explosion in coal mines by using this complete security system, which can reduce the **Loss of Life**. The widely expanding technology LabVIEW is used, where the complete security of the mine is provided by using a single platform, which is more advantageous.

#### V. FUTURE SCOPE

In this security system, each individual can be provided with a Torched Helmet, an Individual Microphone and a Pulse Sensor in the form of a wrist watch to monitor the health status of each individual[3]. This can avoid them in leading to emergency conditions, due to their personal health disorder. In addition the concept of this model can be applied in the gas storage area, where the blast due to gas leakage takes place.

#### REFERENCES

- [1] Paul, P. S. (2009) "Predictor of Work Injuries in Underground Mines – An Application of Logistic Regression Model" **Accepted for the publication in the 3rd issue of the journal of "Mining Science and Technology (Formerly, Journal of China University of Mining Science & Technology)", Elsevier Science.**
- [2] Paul, P. S. and Maiti, J. M. (2008) "The Synergic Role of Socio technical and Personal Characteristics on Work Injuries in Mines" **Ergonomics, Taylor & Francis, UK, Vol. 51, No. 5, pp. 737-767.**
- [3] Maiti, J. M., Dasgupta, S and Paul, P. S. (2005). "Behavioural Safety analysis of the Mine workers – A Case Study" **Mining, Geological and Metallurgical Institute (India) Transactions Vol. 101 pp. 49-59.**
- [4] Paul, P. S., Dey, N. C. and Banik, A. K. (2003) "Postural Problems and Analysis of Loaders, Shovellers and Trammers in Underground Coal Mines", **Indian Mining and Engineering Journal**, Vol. 42, No. 11-12, pp. 27-29.
- [5] Maiti, J. M. and Bruce Wayne (2001) "Mine Accident Data Analysis (MADA) for Identifying Countermeasures towards Better Safety Performance", **The Indian Mining and Engineering Journal**, vol.40.
- [6] <http://coal.gov.in/point18.html>
- [7] [http://fossil.energy.gov/international/Publications/cwg\\_april06\\_safety\\_cil.pdf](http://fossil.energy.gov/international/Publications/cwg_april06_safety_cil.pdf)
- [8] "GSM" [http://www.elettronica.it/EI\\_OnLine/PDF/GSM\\_remote\\_gate\\_opener.pdf](http://www.elettronica.it/EI_OnLine/PDF/GSM_remote_gate_opener.pdf)
- [9] <http://www.dgms.net/DGMS%20Standard%20Note-2010.pdf>
- [10] [http://scclmines.com/home\\_safety.asp](http://scclmines.com/home_safety.asp)
- [11] <http://scclmines.com/downloads/NationalSeminarBRO.pdf>
- [12] [http://scclmines.com/Technology\\_SDL\\_LHD.asp](http://scclmines.com/Technology_SDL_LHD.asp)
- [13] <http://www.coal.nic.in/>
- [14] <http://www.livemint.com/2011/02/23124524/Shortage-of-safety-tech-in-Coa.html>
- [15] [en.wikipedia.org/wiki/Singareni\\_Collieries\\_Company](en.wikipedia.org/wiki/Singareni_Collieries_Company)
- [16] "GASIFICATION" [http://www.fossil.energy.gov/international/Publications/ucg\\_1106\\_cmri.pdf](http://www.fossil.energy.gov/international/Publications/ucg_1106_cmri.pdf)
- [17] Coal India Ltd. Coal reserves in India.
- [18] "ARDUINO"  
a. <http://www.atmel.com/Images/doc8161.pdf>  
b. <http://www.arduino.cc/>
- [19] [http://www.rhydolabz.com/documents/gps\\_gsm/sim900\\_rs232\\_gsm\\_modem\\_opn.pdf](http://www.rhydolabz.com/documents/gps_gsm/sim900_rs232_gsm_modem_opn.pdf)
- [20] [http://www.rhydolabz.com/index.php?main\\_page=product\\_info&products\\_id=460](http://www.rhydolabz.com/index.php?main_page=product_info&products_id=460)
- [21] <http://www.ebay.in/itm/221027607071>
- [22] <gasdetectorsensor.blogspot.com/2012/08/mq-4-gas-sensor-module.html>